



CATALOGUE 2024

[BYNATURE]

*Enjoy. Breathe. Feel good.*



# ByNature

## SPECIALISTS IN BIOPHILIC DESIGN

We create strong connections between nature and the indoor environment.

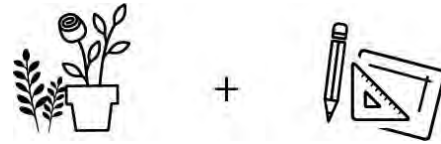

### BYNATURE VISION

Nature plays an essential role in our lives by improving our wellness, happiness, health, and even our productivity. Yet, while we spend 85% of our time indoors, there is still an increasing lack of nature in our living & work spaces.

ByNature believes that any indoor space can be transformed into a healthy living environment. We aspire to bring nature into everyone's lives by creating an experience for people to enjoy, breathe, and feel good.

### BYNATURE MISSIONS







ByNature's team of passionate people are dedicated to using their knowledge of biophilic design principles to enliven your home or office space with nature.

ByNature's vision, however, could not happen without its growing network of visionary partners (architects, designers, landscapers, engineers, and creative visionaries alike). Together, we bring our unique expertise to the table to promote, educate and innovate by creating and sourcing new leading-edge technologies that make your space a better place.

### BYNATURE SERVICES

Consultation - Design - Manufacture - Maintenance - Rental

# CONTENTS

	PRESERVED	4	Mossart	6
			Wall Papers and Domes	12
			Mossart Spheres and Rings	13
			Mossart Logo options	15
			Mixed Moss walls	16
	FAUX	29	BioMontage	21
			Folia Preserved Plants	22
			Preserved Planters	27
			Folia Preserved Trees	28
			Faux Plants	30
	LIVING	33	Faux Flora and Fence Screen Panels	31
			Faux Ceilings	32
			Modulogreen®	34
			Live Pictures and Live Dividers	39
			BioMontage Live	41
	PLANTERS	52	Growmeo®	42
			Felt Pockets	43
			NextGen Living Walls	45
			Earth Studio Living Walls	46
			Serene Walls	49
	FURNITURE	56	Mobile Walls	50
			ByNature Structure	51
			Custom and Self-Watering Planters	53
			Hand Sanitizer Planters	55
			Boxcar Bench	57
	WALL COVERING	63	IPOT	58
			Everything Planter / Everything Table	59
			Babylon Light	60
			Well Planter Light / Well Planter	61
			Orphilia Linear Planter Light	62
			Hemisphere - Pendant - Planter	63
			Naturacork	65
			Gencork	66

# PRESERVED

Our plants and mosses are preserved in an innovative and eco-friendly way using 100% natural oils and food dye. This allows the plants to maintain their authenticity without the need for maintenance.

## WHAT IS A PRESERVED?

Mossart and Folia creations are made with 100% natural mosses, flowers and plants that require no watering, natural light, nor trimming.

Cultivated or harvested according to ecological practices, the mosses, plants and flowers are no longer living and require little to no maintenance. They are preserved without the use of chemicals by using both a natural oil and natural food dyes. As the oil mimics the water in the plant, they still appear live and can maintain a natural appearance for months or years to come (6 months to 5-10 years for plants/flowers and 8+ years for the preserved mosses; please refer to life expectancy of individual plants).

## HOW TO MAINTAIN PRESERVED MOSSART OR FOLIA PIECES?

Preserved products are for indoor-use applications only and their softness may vary according to the relative humidity of the room. In the case of a very dry environment (below 30% humidity), the REINDEER moss or plants may become dry or harden. Once returned to normal room temperature and humidity levels, however, it may become soft again. This variation is usually related to the season. A relative humidity considered as "normal" is between 45 and 65%.

Be aware that the "softness state" of the plant does not change its look. Once returned to normal room temperature and humidity levels, however, the reindeer moss will become soft again. When near end of life expectancy, preserved plants and flowers may begin to dry and as a result change form. Replanting or touch-ups may be requested at this stage. Never water or spray preserved products and avoid keeping them in direct sunlight for prolonged periods. This will help ensure the preserved products reach their longest life expectancy and maintain their colour, shape and texture.

## IMPORTANT NOTES

You may experience a natural scent for a few months, which will progressively fade. If required, the moss may be carefully dusted using a blow dryer on a low temperature setting.

Preserved products are natural and will usually have some varieties in colour.



# MOSSART

Our Mossart creations are 100% natural and made with preserved moss. Mossart products are no longer living and do not require any natural light, trimming, or watering.

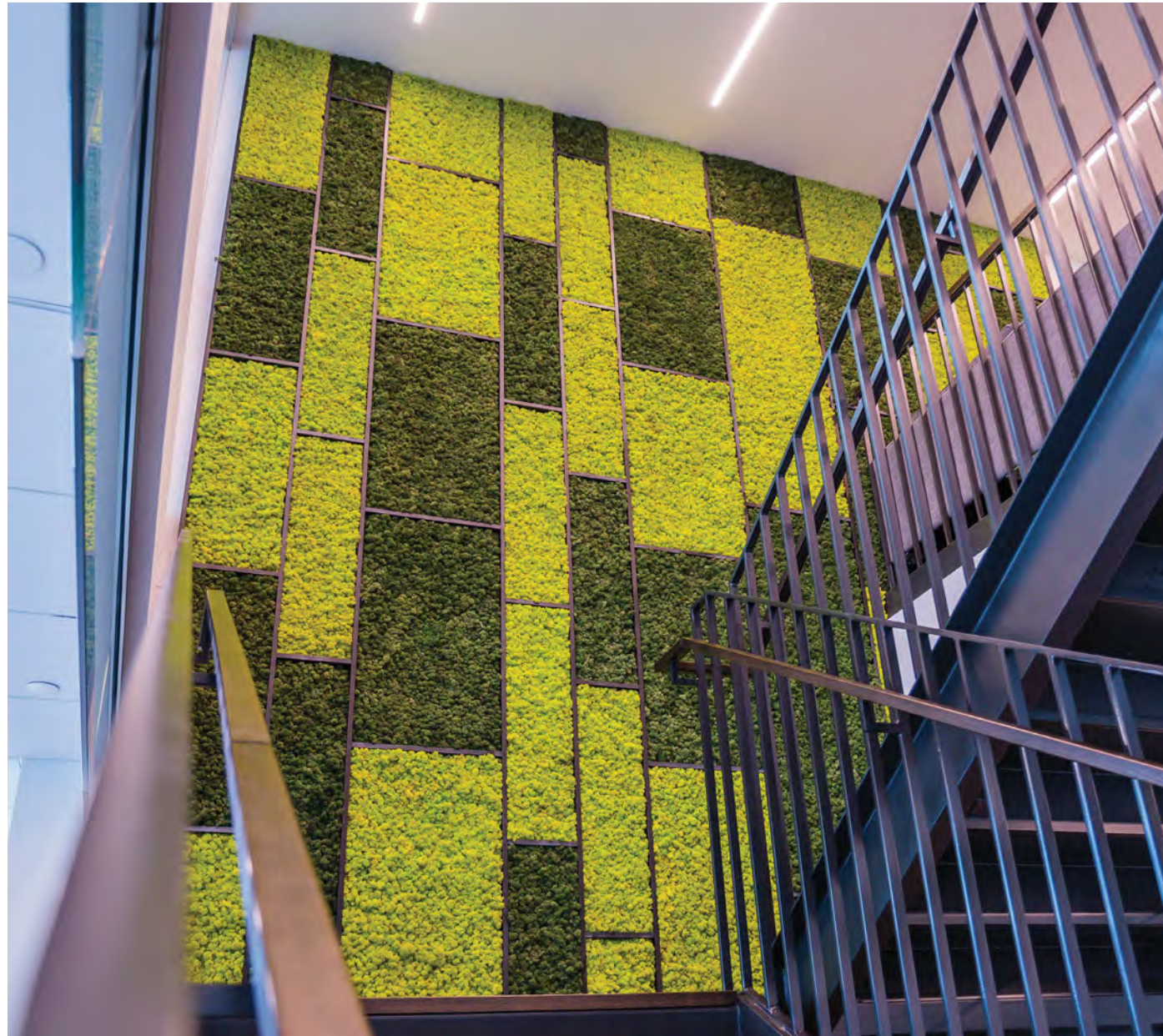

## MOSSART PANELS



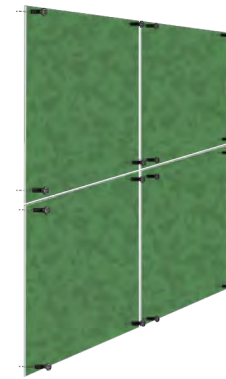

For wall applications



### PANEL INSTALLATION

- Pre-made panels
- Simply screw panels in place
- Custom sizes and shapes
- Seamless look

### BACKING OPTIONS

-  Ecofelt (made of recycled plastic bottles)
-  Flexifelt (curved surfaces)
-  Cork
-  Wood
-  Coroplast\*

*\*Standard backing is Coroplast. Other options are available for additional fees.*

## MOSSART EDGES

Available finishes for edges



Bare Edge



Mossart Edge

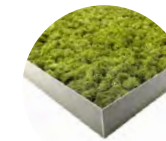

Aluminium Trim



Wooden Trim



Wooden Frame

## MOSSART IN A FRAME

Wood frame options



Ash Whitewashed



Ash Clear



Walnut Stained



White Painted

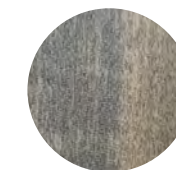

Grey Stained



Ink Black

CUSTOM OPTIONS AVAILABLE

# REINDEER MOSS

ByNature Reindeer Moss, actually a lichen, is our most popular moss for both large and small applications. From natural to bold shades, Reindeer Moss comes in 19 different colours to create unique and lush designs.

2" thick and dyed using food grade dye. Custom colours available for large volumes. Non-dyed natural coloured moss also available.



Dark Green

## TEXTURE OPTIONS

Grade A

Higher quality using only the top part of the moss.



Grade B

Made with top and bottom parts of the moss.

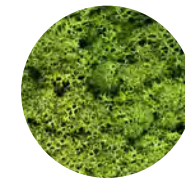

Dark Green

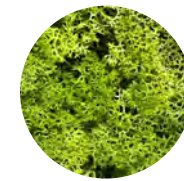

Medium Green



Olive

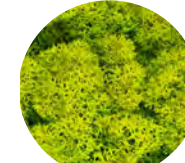

Spring Green

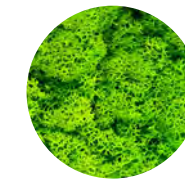

Grass Green Light



Grass Green



Pine



Mint



Natural



Silver Grey

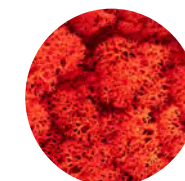

Red

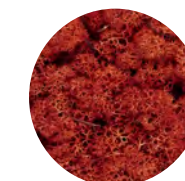

Sienna

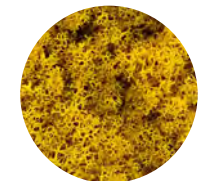

Yellow



Lemon



Orange

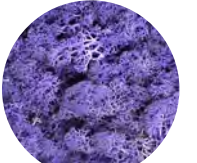

Purple

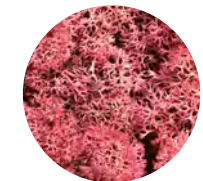

Burgundy



Pink

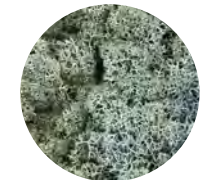

Ice Blue

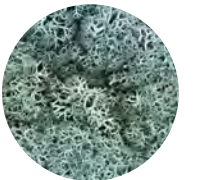

Blue Lavender

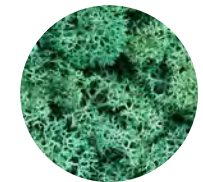

Pacific Blue

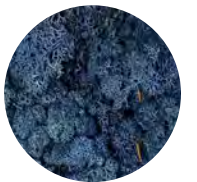

Azure

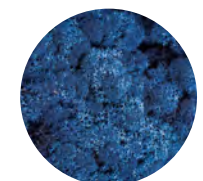

Classic Blue



Charcoal

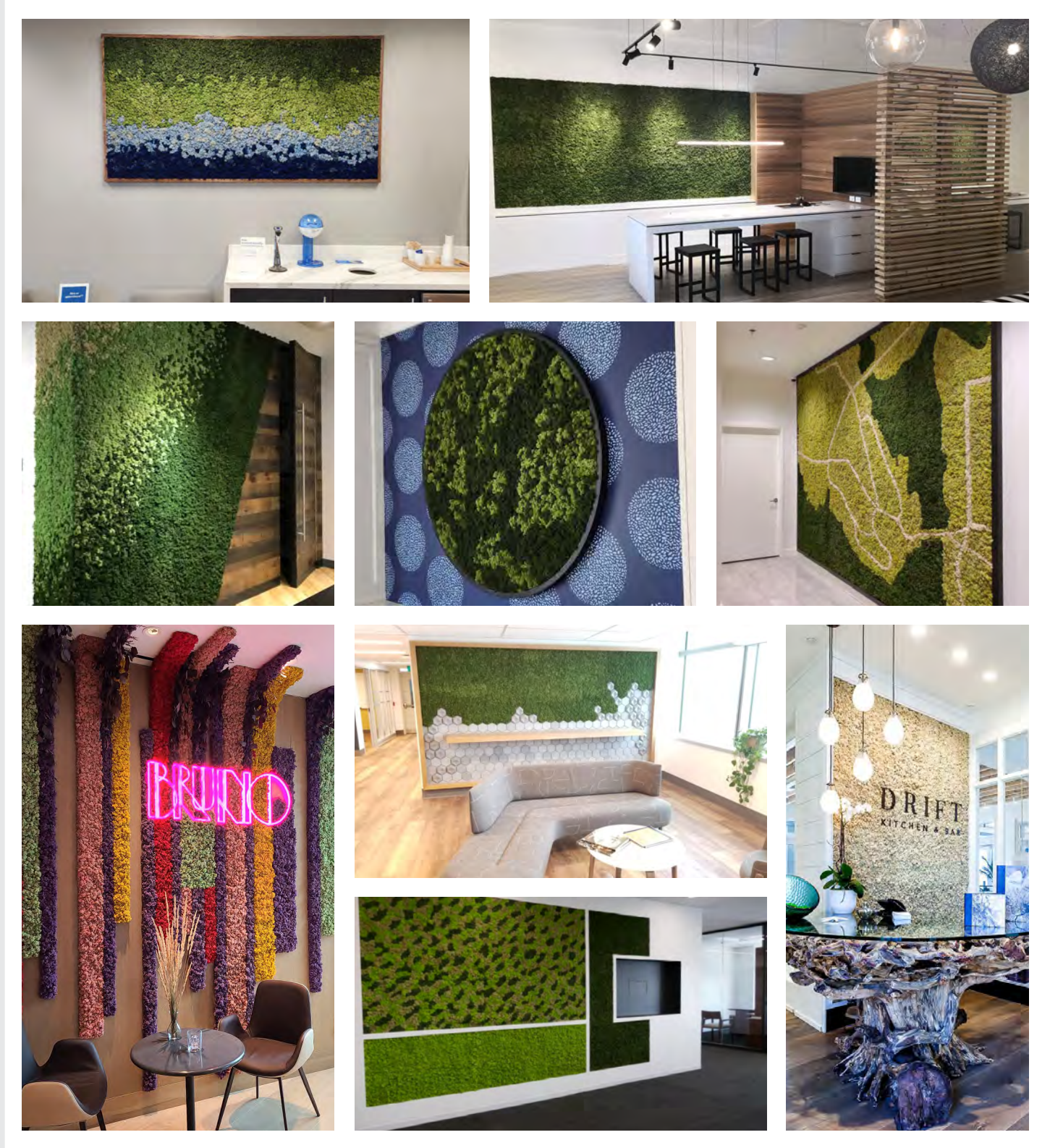

## WALL PAPERS

Entire walls can be covered by repeating patterned tiles

1. Pick your moss species

2. Pick your colours

3. Pick your pattern

Most popular patterns

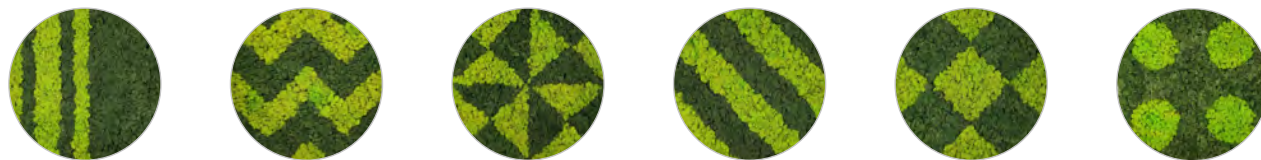

## DOMES

Domes are lightweight circles that are easily mounted to a wall to assist with sound absorption in a room. They add a unique decor element to any room and can be created in any of our Reindeer Moss colours for your perfect fit.

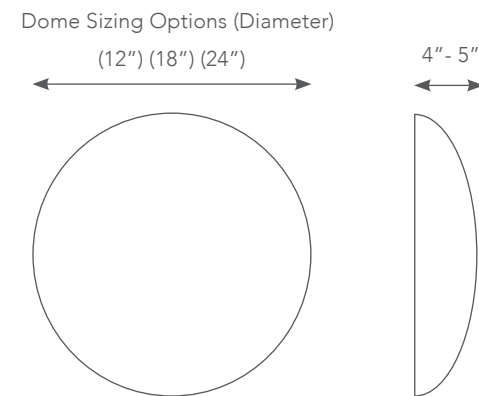

Custom sizes available upon request



## SPHERES

Spheres are lightweight moss balls with sound dampening properties that are designed to be suspended from the ceiling. They are made from Reindeer Moss and can be ordered in any of the colours we stock.

Sphere Sizing Options (Diameter)

(3") (6") (8") (12") (16") (24") (30")

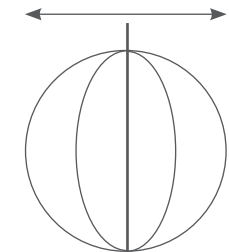

Custom sizes available upon request



## RINGS

Rings are moss circles in beautiful, round, natural wood frames that can easily be hung onto your wall or set on a table as a decor piece. You can choose any moss type and colour that we stock to fill your frame, giving you a larger variety of textures and colours to design with.

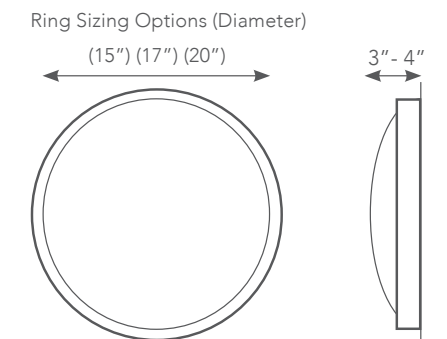

Custom sizes available upon request

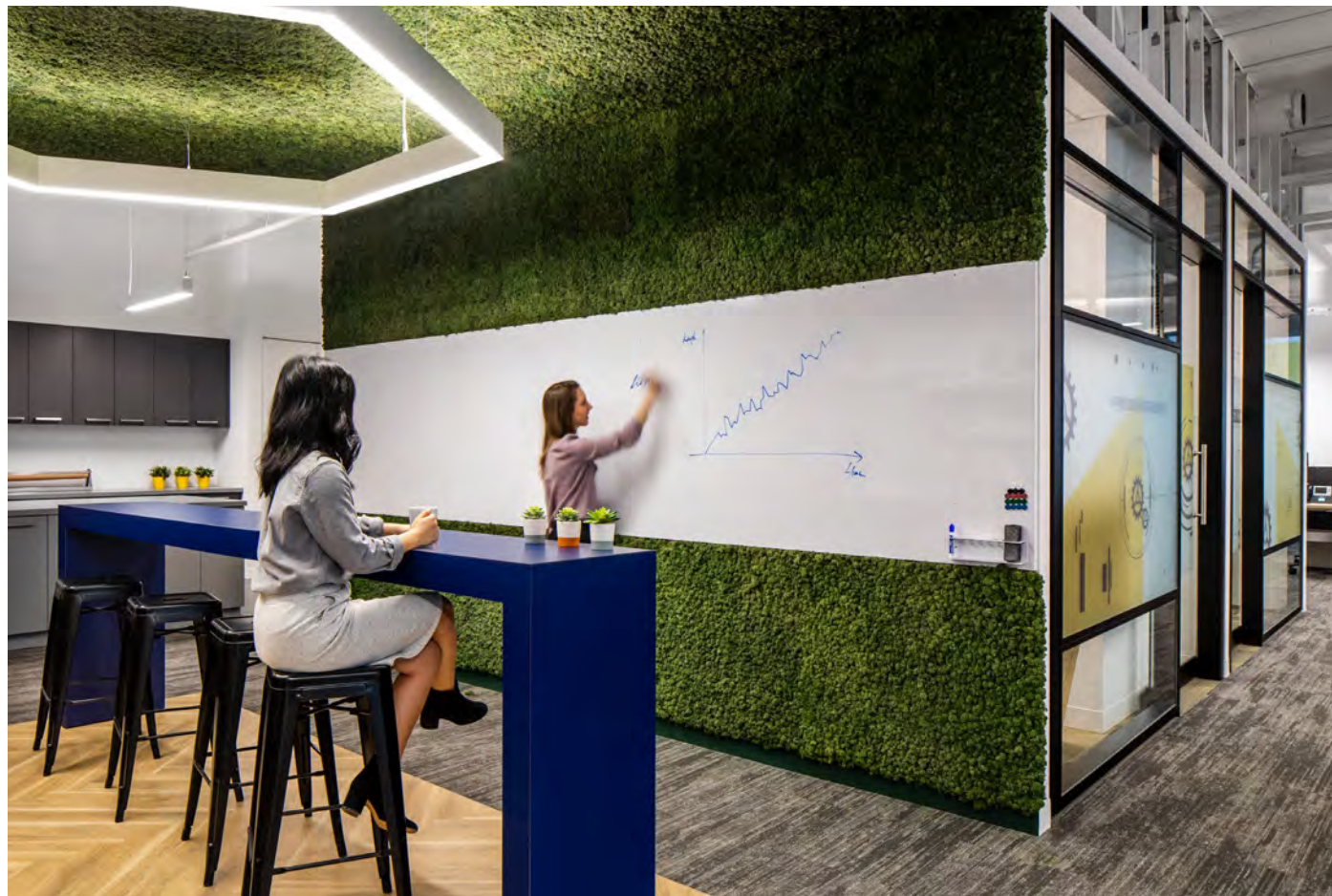

### ACOUSTIC FUNCTION

Mossart Panels have significant sound-absorption.

According to a study conducted by the Centre for Architectural Ecology at the British Columbia Institute of Technology (BCIT), sound absorption is relatively high with signal number ratings (NRC and SAA) in the range of a 3/4"-1" fibre board, or a carpet on underlay pad.

Absorption in this range can be useful in classrooms and conference rooms to improve speech intelligibility and the quality of verbal communication.

### FLAMMABILITY

ByNature unicolour reindeer Mossart Panels have been tested for flammability.

The method, designated as CAN/ULC-S102-10, Standard Method of Test for Surface Burning Characteristics of Building Materials and Assemblies", is designed to determine the relative surface burning characteristics of materials under specific test conditions.

After testing three identical specimens, results confirmed that ByNature Mossart panels have an average Flame Spread Rating (FSR) of 95 and an average Smoke Developed Classification (SDC) of 445.

## MOSSART LOGO OPTIONS

A logo is a key element of an organization's visual identity. Adding your custom-built logo to your office lobby, reception area, waiting room, meeting room or restaurant creates a memorable branding of your organization's professional space.



ACRYLIC



ACRYLIC CHANNEL LETTERS



CUT LETTERS COVERED

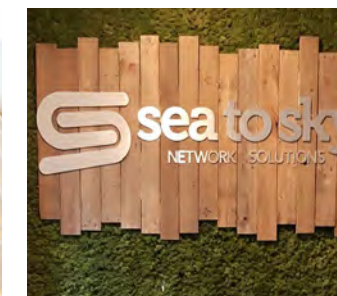

WOOD LOGOS



METAL CHANNEL LETTERS



WOOD CHANNEL LETTERS



METAL LETTERS



EMBEDDED WOOD LETTERS



MOSS LOGO

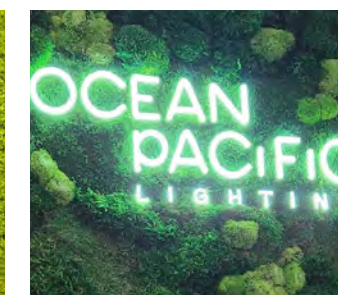

NEON LED SIGN



BACKLIT



# MIXED MOSS WALLS

With its organic mix of mosses, this is one of the most natural looking Mossart wall application we have.

(c) photo: teatrix inc.

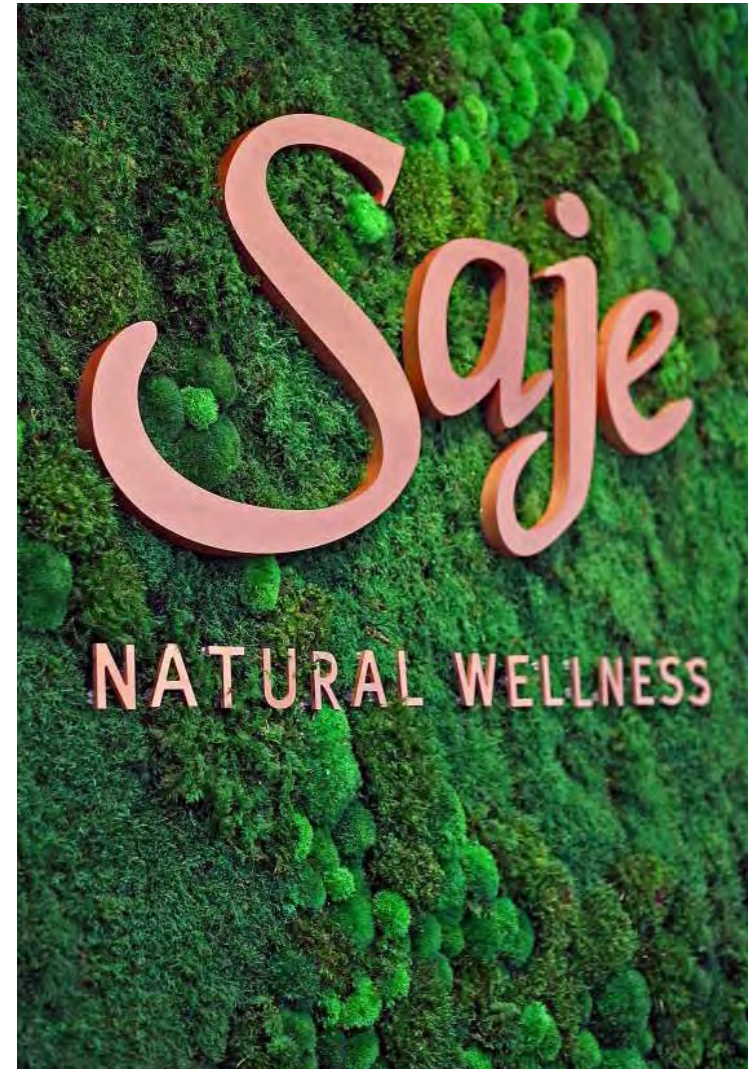

# POLE MOSS

ByNature Pole Moss adds a chic and modern element to any space. Pole moss can be used to create original décor and is usually used in wall or ceiling applications. It is available in many different shades, preserved and dried. Standard panels are approximately 2" to 3" thick.



# TEXTURED MOSS

Our unusual textured moss species introduce a subtle, additional texture and visual appeal to any project. These lesser-known types of moss are ideal for bringing interesting natural textures and depth of colour to projects.

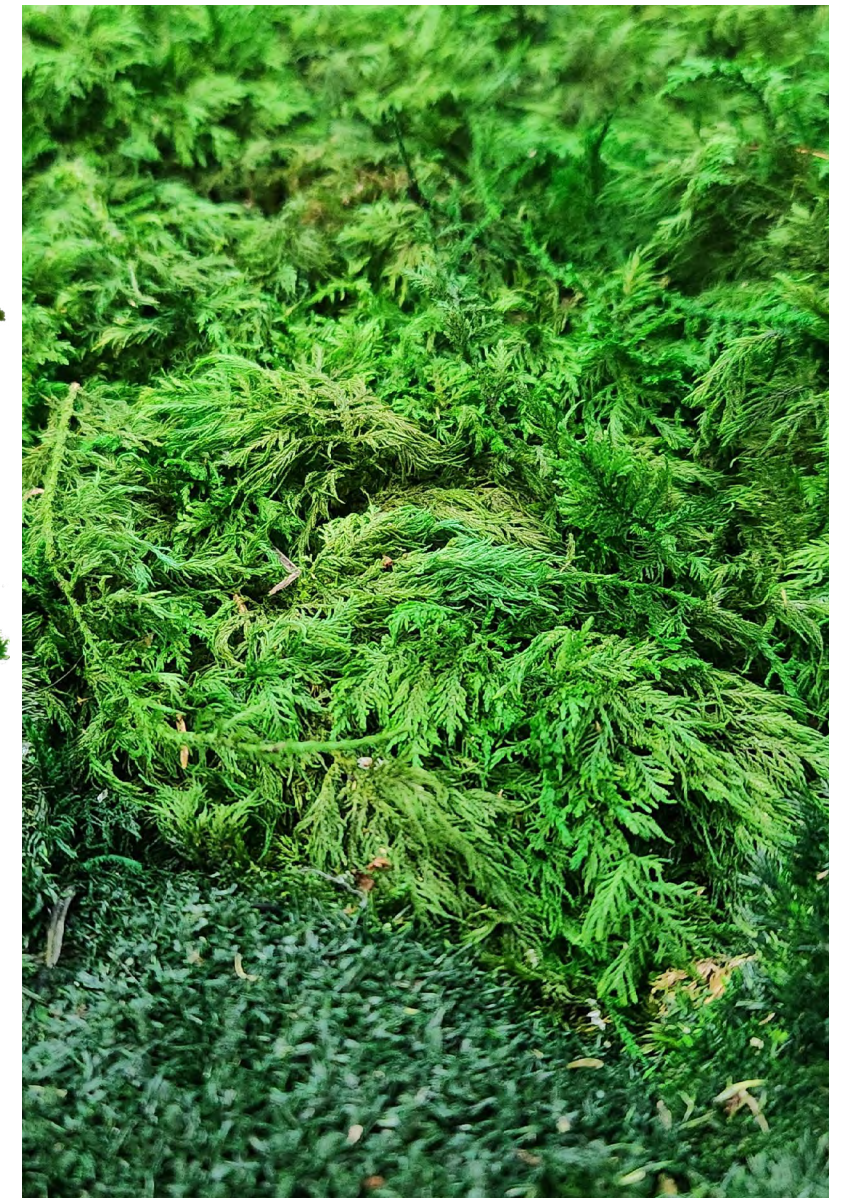

Colombian moss



## SHEET AND ROCK MOSS

ByNature Sheet and Rock Moss brings a very natural and organic feel to a space. Sheet and Rock moss can be used to create original decor and is often applied as a wall or ceiling covering. It exists in different shades of green, preserved and dried. Standard panels are approximately 3/4" thick.



-  Preserved Sheet Moss Dark Green
-  Preserved Sheet Moss Light Green
-  Dried Sheet Moss
-  Preserved Rock Moss Light Green

## BIOMONTAGE

The BioMontage system is an easy to install, two-piece frame that holds a ByNature Moss, Folia or preserved panel for a clean & natural detail built into your space. Inserts can easily be changed to create a new look.



ALL PRESERVED OPTIONS, MOSSART AND FOLIA AVAILABLE WITH BIOMONTAGE

### THE BIOMONTAGE SYSTEM

- Fire-resistant, easy to install frames
- Patent Pending design allows for quick and easy changes of natural material inserts
- Purchase multiple inserts for flexible design options
- Frames available in Black and White

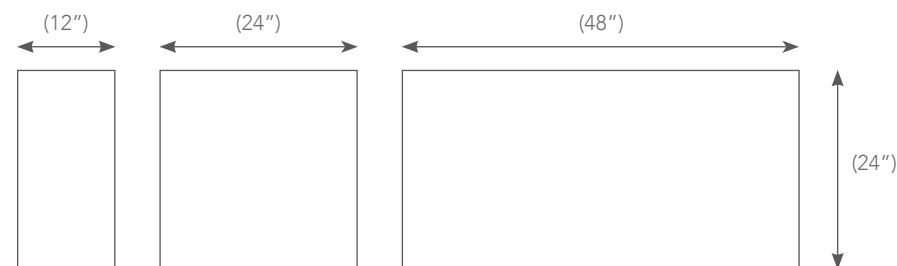

### PANEL SIZES & FINISHES

Mossart and Folia are available with the BioMontage system, as well as Light Stone, Sustainable Bark, Upcycled Coconut and Manjium Tree.

(For more details, ask for the full brochure)

## FOLIA PRESERVED PLANTS

ByNature's exclusive line of 100% natural and preserved foliage can be used to create an array of distinctive pieces including table centre pieces, unique frames, ceilings and wall coverings. This natural décor will last for years with limited maintenance (no natural light, trimming or water required).

- No size or design limitations
- 70+ plant varieties available
- 20+ flower varieties available
- 100% natural
- No maintenance, water or light required
- Long lasting preserved natural décor

### AVAILABLE FORMATS

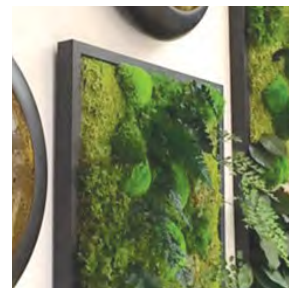

Frames



Walls



Bulk Foliage



Custom



CONTACT US FOR FULL CATALOGUE OF PRESERVED FOLIAGE AND FLOWERS



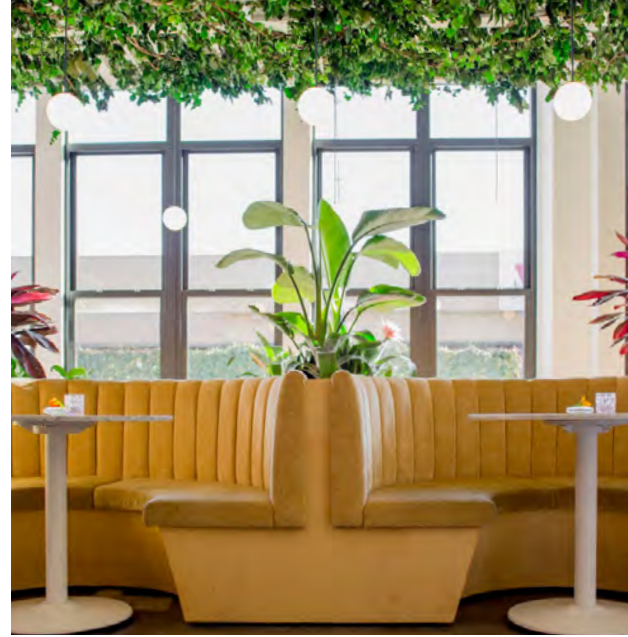



## PRESERVED PLANTERS

Using our 100% natural preserved plants, Preserved folia planters allow for a maintenance free planter that can be inserted into any previously owned or new planters. These beautiful green additions are a wonderful option to add preserved plants without having to drill or hang anything on the wall!



# FOLIA PRESERVED TREES

ByNature's exclusive line of trees are 100% naturally preserved. Using an innovative process, moisture in the plant is replaced with a vegetable-based glycerin solution, a component that does not evaporate over time. This process preserves the tree's natural feel and beauty for years with limited maintenance required (no natural light, trimming or water required).

- No maintenance, water or light required
- Long lasting preserved natural trees
- More than 50 different species
- Sizes ranging from 1 ft to 20 ft
- 100% natural

LARGE DIVERSITY OF SIZES, SHAPES, TEXTURES AND COLOURS AVAILABLE.



# FAUX

Faux plants give you the freedom to get truly creative with the spaces you have, be it at home or work. Dark corners, no windows or limited space are not a problem. Tailor the landscape to suit your design, no need to worry about the plant altering or changing over time.

## FAUX PLANTS

A great imitation of nature, the authentic colours and textures mimic living plants perfectly and like real plants, have a positive impact on the way people feel in a space. When living or preserved plants do not work in a space because of indoor environmental conditions, these exquisite faux plants become the best option.



MORE THAN  
1000 OPTIONS  
AVAILABLE



## FAUX FLORA AND FENCE SCREEN PANELS

Faux Flora Panels are used to create stunning vertical gardens. This product will bring the organic shapes and colours of nature to your space with zero maintenance.

### FAUX FLORA

- 5x panel styles available
- Each panel measures 35.5 x 35.5"
- The panels can be cut to fit bespoke areas
- Fire and UV solar weather tested foliage
- Light weight aerated system
- No maintenance



All Green



Lush Green Plus  
Yellow



Luxury White



Designer Wall

### FENCE SCREEN

- 3x panel styles available
- Each panel measures 20 x 40"
- The panels can be cut to fit bespoke areas
- UV stable HDPE lightfast colour pigments
- Proprietary RealLeaf® Technology
- No maintenance



Rainforest



Maui



Kauai

FOR MORE DETAILS,  
ASK FOR FULL  
BROCHURE

### FAUX FLORA PANEL

Each faux flora panel has been carefully designed to mimic the growing patterns and movement of natural foliage and to prevent any visible repetition in planting.

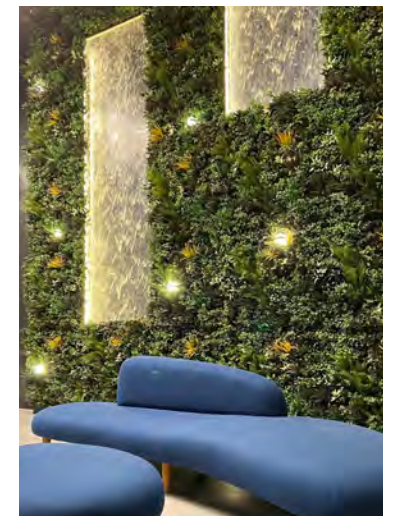



## FAUX CEILING

ByNature's faux ceiling installations are a beautiful way to add cascading greenery from above, without the natural limitations of our live or preserved products. The wide selection of faux plants ensures you will have a truly unique installation in your space.

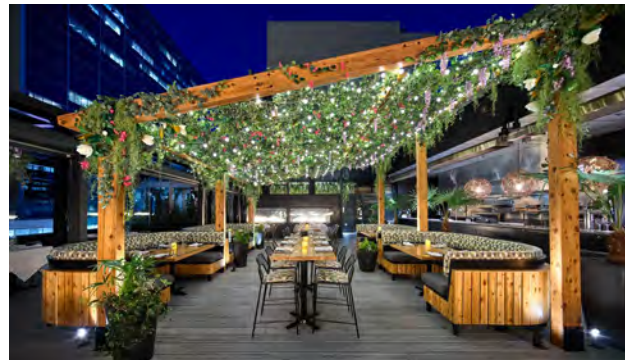

## LIVING

Living plants clean indoor air by absorbing toxins, increasing humidity and producing oxygen. Adding live plants to an office space can be used to create privacy, reduce noise and improve overall air quality.

# MODULOGREEN®

Plants thrive when they grow in rich, natural soil with access to regular light and water. That's why we designed the ModuloGreen® Living Wall which comes with a special substrate to ensure optimal plant growth, low maintenance and water consumption requirements. ModuloGreen® Living Walls are also easy to install and one of the most cost-efficient for both you and the environment.

FOR MORE DETAILS,  
ASK FOR FULL  
BROCHURE



## MODULE SIZES & FEATURES

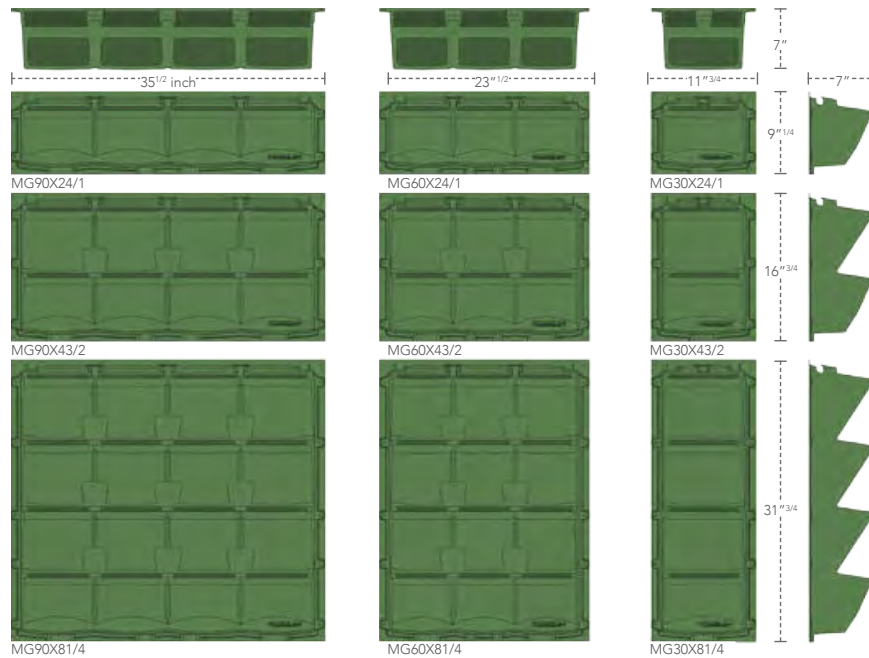

- low cost
- biodiversity
- low maintenance
- wall protection
- phonic absorbent
- sustainable
- energy saving
- low in water consumption
- easy to install
- large plant diversity
- easy planting
- recyclable
- engineered growing medium
- C2C® certified

ModuloGreen® Living Wall is the first Cradle-to-Cradle certified living wall system in the world. Made from recycled plastic and recyclable after use, the smart design of the module also evenly distributes and circulates water while optimizing the system's water consumption (220 litres / m2 / year for an exterior living wall or 110 litres / m2 / year for an indoor wall).



## PANEL INSTALLATION

Modulogreen® green walls are mounted using a wide diversity of methods and materials with the idea of keeping installation easy. Traditional studs can be used for small indoor applications while engineered brackets can be used for outdoor large scale applications. Traditionally, air space between the wall and the living wall is created to limit the risk of condensation.

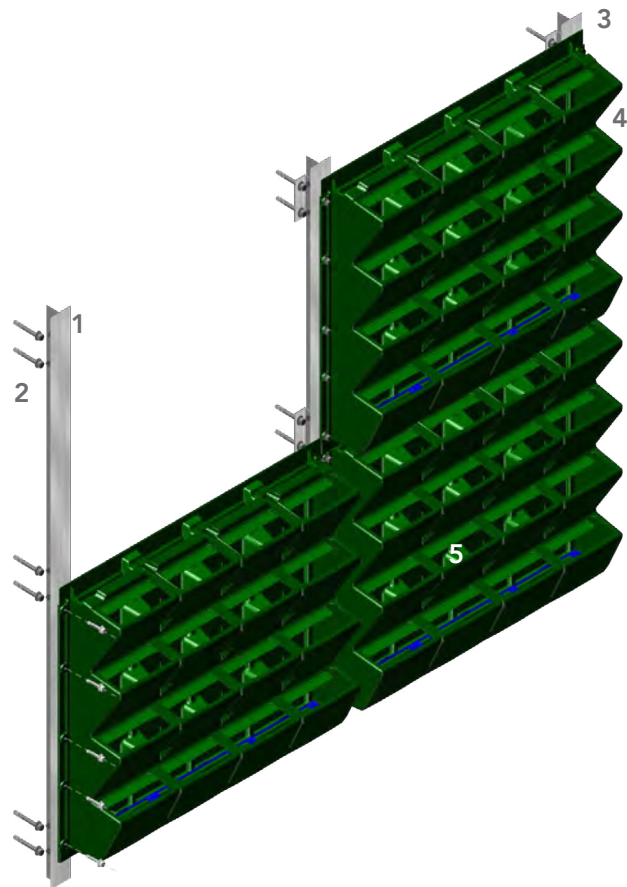

1. Aluminium brackets/studs
2. Stainless steel self-drilling screw/anchors
3. Self-regulating dripline
4. Planting cells
5. Filter

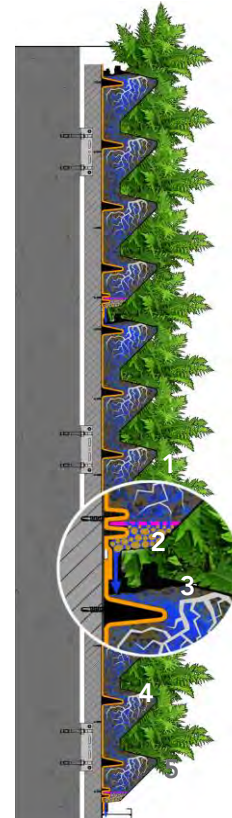

## WATER DISTRIBUTION

1. Filter + draining layer
2. Drainage holes
3. Internal water distribution
4. Growing medium
5. Collecting gutter



## IRRIGATION

1. Controller
2. Valves (variable numbers)
3. Fertilizer injector mounted in by-pass
4. Filter
5. Pressure regulator with gauge
6. Check valve
7. Water inlet (disconnected)

Proper irrigation of a green wall requires a dedicated water supply. Ideally, a living wall system should be plugged into the main water supply with an automatic irrigation system (pictured on the left) or irrigated with rainwater (if outdoors). If there is no access to water, a reservoir connected to a pump and timer assembly can be installed or hand watered.





## LIVE PICTURES & LIVE DIVIDERS

All Live Systems use a cloth wick to deliver water to the plants, so there is no need for pumps, drip lines, electricity or plumbing.

- Low maintenance; water once every 3-4 weeks
- Easy installation - no plumbing or electricity required
- Lightweight system can be installed directly onto drywall
- Easy cassette replacements and seasonal rotations
- Interchangeable plant cassettes
- Wicking irrigation system
- Customizable frames

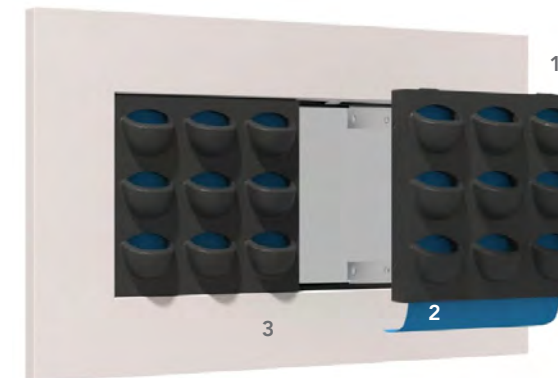

### SYSTEM

1. Cassette (9 four inch plants each)  
15.75 x 15.75 x 3.5 inch
2. Cotton wick
3. Gutter/reservoir

FOR MORE DETAILS,  
ASK FOR FULL  
BROCHURE

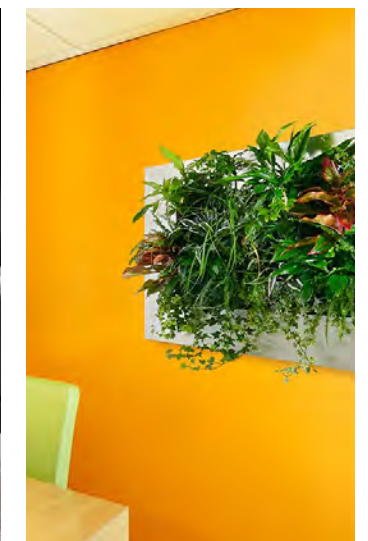
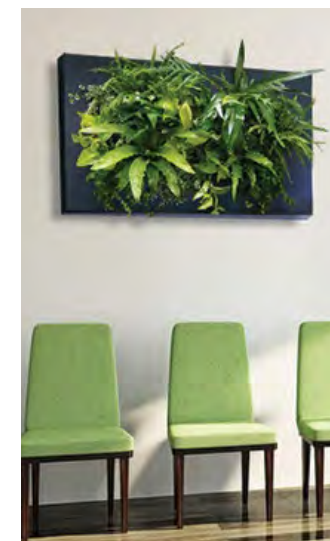



**LIVEPICTURE 1**  
28.5 x 28.5 x 2.75 inch - 26.5 lb  
Holds 9 plants



**LIVEPICTURE 4**  
76 x 28.5 x 2.75 inch - 56.0 lb  
Holds 36 plants



**LIVEPICTURE 2**  
44.5 x 28.5 x 2.75 inch - 36.5 lb  
Holds 18 plant



**FREESTANDING LIVE DIVIDER**  
71 x 44.5 x 5.5 inch



- 54 four inch plants per side
- 205 lb (single sided)
- 282 lb (double sided)
- 20 gallons water capacity



**LIVEPICTURE 3**  
60 x 28.5 x 2.75 inch - 46.5 lb  
Holds 27 plants



# BIOMONTAGE LIVE

Biomontage Live has its own indicator that will let you know when the water tank needs filling. Biomontage Live has a capillary feature within the planted pots ensuring the plants are supplied with the correct amount of water without you needing to think about it.

● BML-B    ○ BML-W    24" x 24" x 2.75" (Lx H x D)

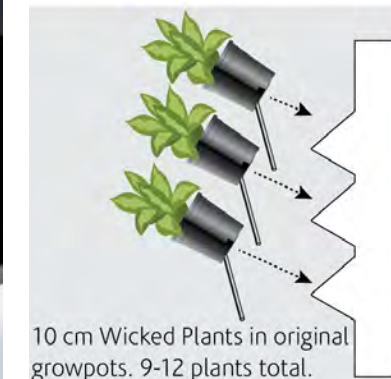
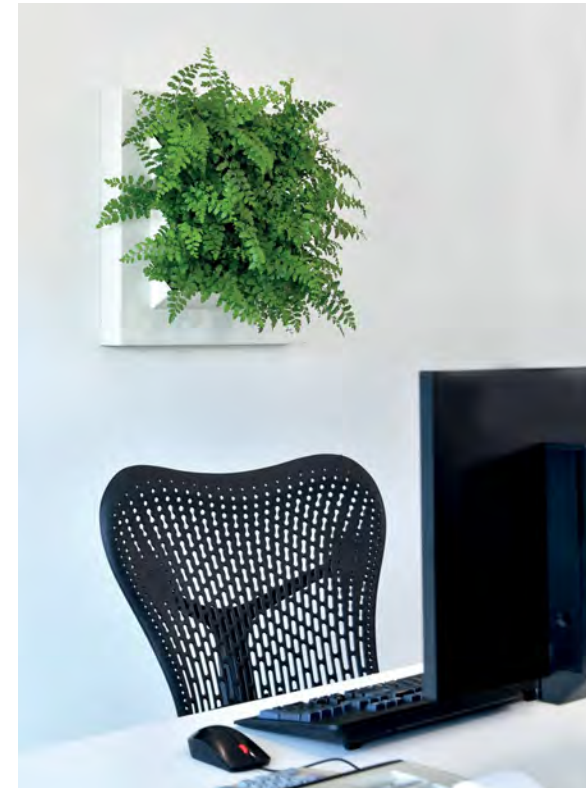

# GROWMEO®

Growmeo® is a living wall system. Through capillary action the plants passively absorb water from the bottom reservoir through a specialized wicking layer embedded within the growing medium. The wicking layer provides an ideal amount of moisture and aeration, eliminating the need for drainage and reducing regular maintenance.

Growmeo® is ideal for purifying the air and bringing a little bit of the natural world into any interior space!

**GROWMEO®**  
24 x 26.5 x 4 5/8"

**GROWMEO® MINI**  
17.5 x 19 5/16 x 4 5/8"



# FELT POCKETS

The use of Felt Pockets is the most affordable way of creating living walls. Quickly and easily create lush green walls and vertical gardens on any indoor or outdoor wall, fence or railing. Design living walls of any shape or size by combining multiple pockets together.

- Affordable living wall solution
- Simple maintenance
- Easy installation

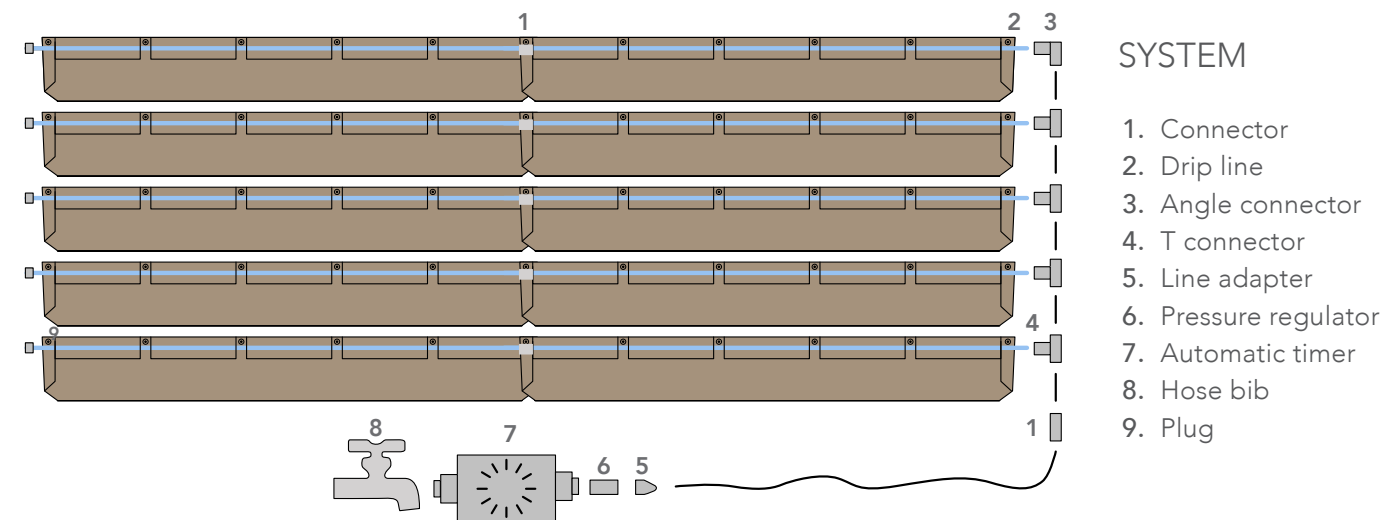

## SYSTEM

1. Connector
2. Drip line
3. Angle connector
4. T connector
5. Line adapter
6. Pressure regulator
7. Automatic timer
8. Hose bib
9. Plug



**FELT ONE**  
15 x 24 inch  
WA1BK WA1BR



**FELT THREE**  
15 x 68 inch  
WA3BK WA3BR



**FELT FIVE**  
15 x 112 inch  
WA5BK WA5BR



## NEXTGEN LIVING WALLS

Easy to install and to plant, "plug and play" system, virtually any kind of plant can thrive in the NextGen Living Walls.



- Works with plants in their original grow pots
- Plug and play system
- Easy plant rotations
- Easy maintenance
- 3-4 weeks watering cycle

FOR MORE DETAILS,  
ASK FOR FULL  
BROCHURE

## EARTH STUDIO LIVING WALL

Earth Studio is a modular, vertical garden system. Inspired by nature's ultimate gardeners: bees. The honeycomb-designed pockets enable a number of configurations suitable for any space.



- Automated system
- Flexible, fast, fullness guaranteed
- Design flexibility
- Indoor or outdoor
- Remote monitoring unit
- Recycled

FOR MORE DETAILS,  
ASK FOR FULL  
BROCHURE

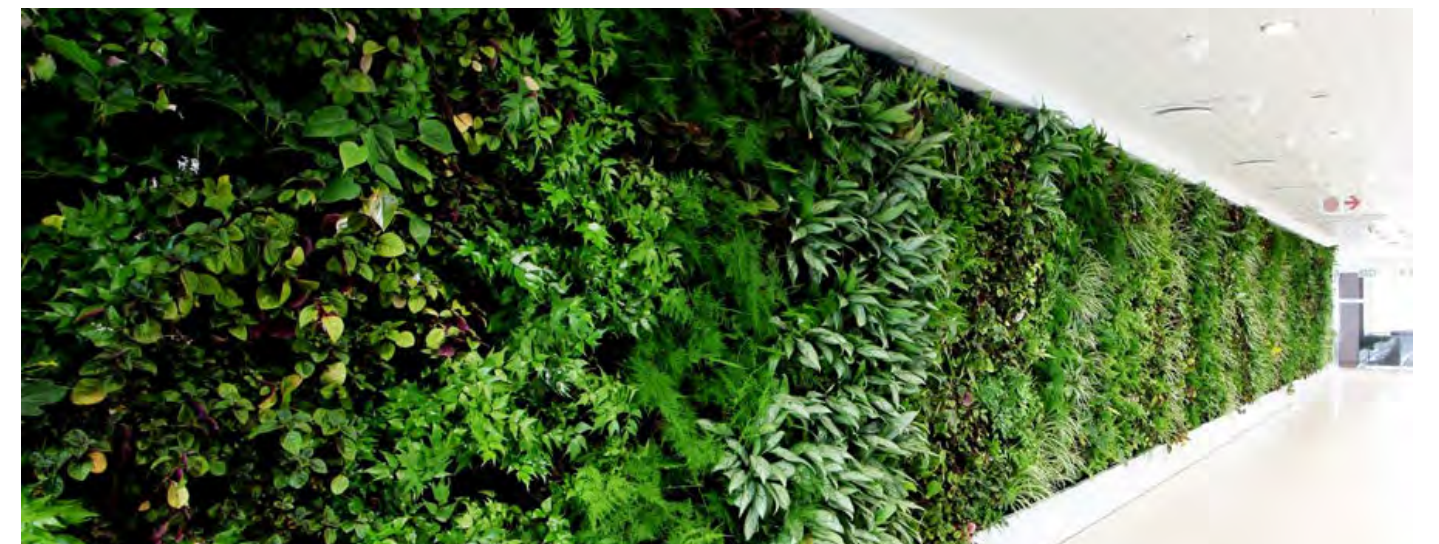





## SERENE WALLS

Serene is the same trusted Earth Studio living wall but with the water tank, pump and irrigation fully integrated into the frame.

- No gaps
- Hidden tanks
- Water is circulated through an irrigation system and filters slowly from pot to pot back into the tanks
- Optional remote monitoring device
- 35 bags, 35 pots
- 5" - 6" plants recommended
- Frame size: 77"x35" (1950 mm x 875 mm)

Included: frame, water tank, pump, irrigation, and wall bracket or base plate.

Colour choices  White  Black



FOR MORE DETAILS,  
ASK FOR FULL  
BROCHURE

## MOBILE WALLS

In consideration of evolving needs for organized, functional, individual work areas, within open space, these flexible mobile walls are the perfect solution.

- Great partition walls
- Easy to move around the space
- Available in one-sided and two-sided models
- Sturdy cover to hide frame
- Available with Preserved, Living and Faux options



(41" wide)

STRUCTURES AVAILABLE WITH MOSSART FOLIA, FAUX AND LIVING OPTIONS



## BYNATURE STRUCTURE

This structure is a ByNature original product made in Canada.

- Customizable structure
- Can be single-sided or double-sided planted
- Can be planted with living, faux or preserved plants
- Optional self-watering reservoirs
- Made in Canada

### FINISH



White Metal finish



Wood

### SIZE

Standard:  
96" x 43 1/2" x 12 1/2"

SIZE CAN BE CUSTOMIZABLE

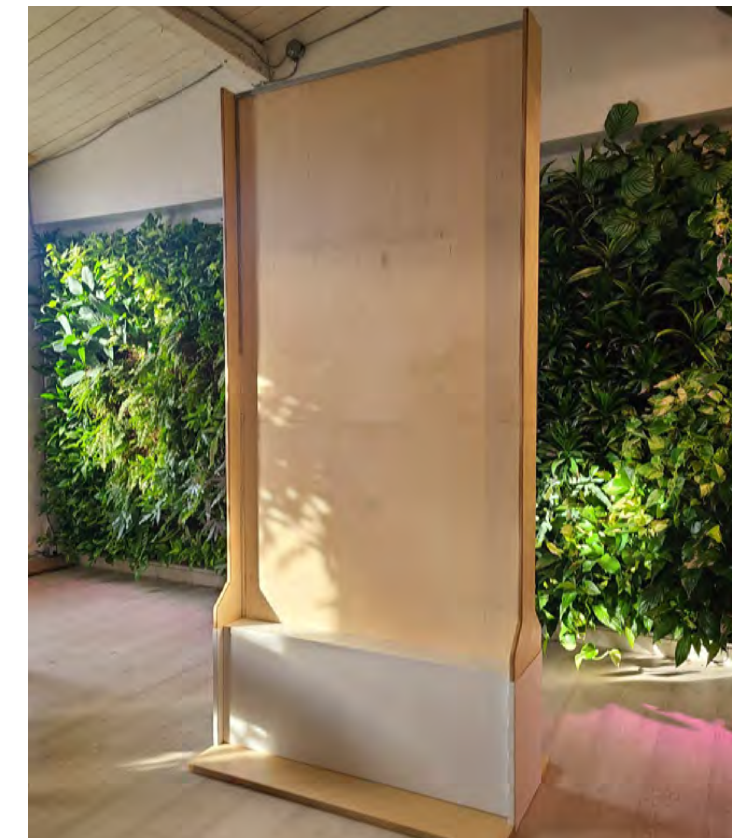



# PLANTERS

ByNature is proud to announce that we can now accommodate your planter requests. We can customize (colors, shape and sizes) planters out of aluminum, stainless steel as well as fiber glass.

ByNature also supplies liners and self watering systems that can be integrated to any planters.

## CUSTOM AND SELF-WATERING PLANTERS

Our Self-Watering Planters allow you to have live plants without the maintenance of traditional planters. Various designs and sizes available for tabletop and floor.

- Fill the water reservoir once every 4 to 6 weeks (water from the top for the first 8 weeks)
- Floor and tabletop designs available
- Wicking irrigation system
- Over 200 colour & style options
- Custom designs available
- 6 available finishes: stainless steel, plastic, aluminum, fiberglass, concrete and clay

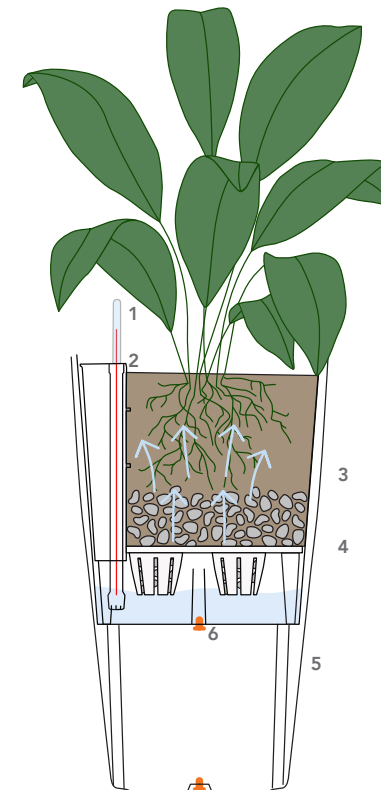

BYNATURE DISTRIBUTES SEVERAL PLANTER LINES IN VARIOUS FINISHES. ASK US FOR MORE DETAILS.

### SYSTEM

1. Water level indicator
2. Water supply shaft
3. Lechuza® absorbing aggregates
4. Separator
5. Water reservoir
6. Drain plugs





# HAND SANITIZER PLANTERS

Those planters are manufactured to WHO standards. These are the first planters combining living and the fight against the spread of Covid 19. Each unit include a 5L hand rub dispenser.



**FLORENCE**  
350mm x 1200mm

- Hero Grey
- Cool Grey
- Clinical White



**MARIE**  
300/400mm x 1200mm

- Hero Grey
- Cool Grey
- Clinical White



**LOUIS**  
350mm x 350mm x 1200mm

- Hero Grey
- Cool Grey
- Clinical White



# FURNITURE

ByNature believes that greenery should be part of our every day decor. That is why we offer a furniture line that can integrate our living and preserved products in their design. It is now very easy to add plants in your indoor space!

## BOXCAR BENCH

The Boxcar Bench is a beautiful example of the simplicity of good design. Blending quality minimalism, functionality and authentic materials, its aesthetic will elevate any space. A fit for commercial, residential, public or private settings, the Boxcar is a stunning way to incorporate nature with function that will stand the test of time.

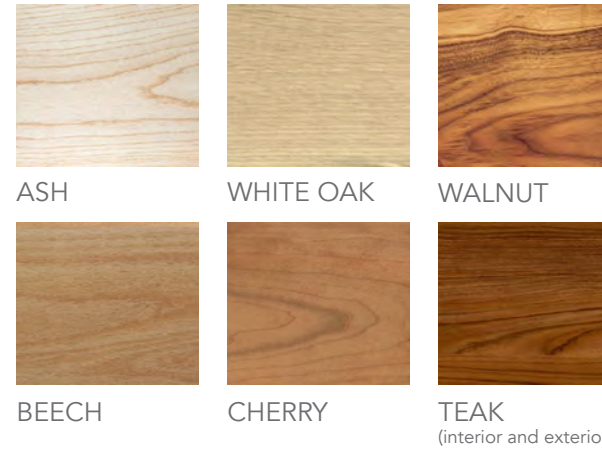

95" L x 27" W x 19" H  
Optional stainless steel planter – 12" W x 10" H

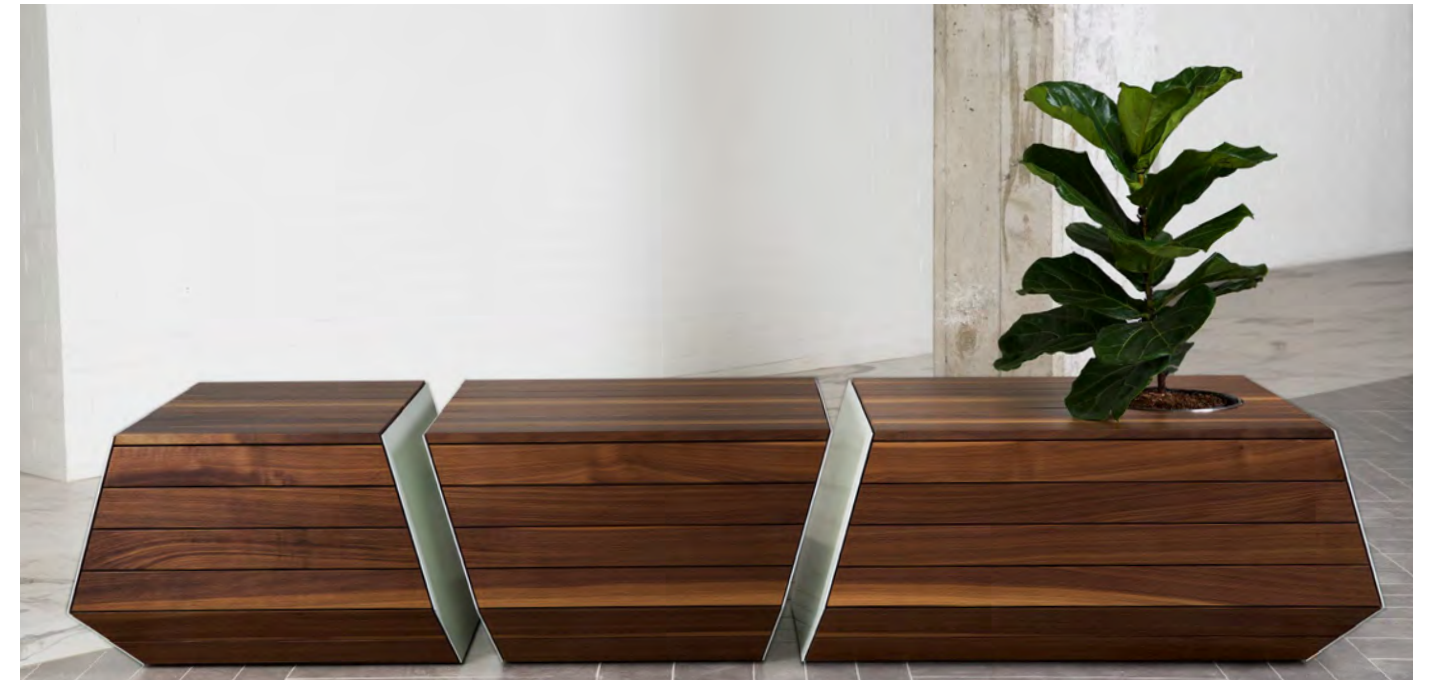







# I POT

iPot is a modular system able to take on an unlimited number of shapes. The structure is assembled by combining lightweight elements via interlocking aluminum tubes and plastic joints. It can be made and re-made.



CUSTOM SIZES AVAILABLE AS WELL AS OTHER MODULAR ADD-ONS (PLANT POUCHES OR SHELVES)

 <p><b>2X DIMENSIONS</b> 21.5 x 42.0 x 21.5 cm Included add-ons: 1 bag</p>	 <p><b>2X DIMENSIONS</b> 42.0 x 21.5 x 21.5 cm Included add-ons: 1 bag</p>	 <p><b>4X DIMENSIONS</b> 42.0 x 42.0 x 21.5 cm Included add-ons: 2 bags</p>
 <p><b>4X DIMENSIONS</b> 83.0 x 21.5 x 21.5 cm Included add-ons: 2 bags</p>	 <p><b>9X DIMENSIONS</b> 62.5 x 62.5 x 21.5 cm Included add-ons: 2 bags</p>	 <p><b>9X DIMENSIONS</b> 83.0 x 62.5 x 21.5 cm Included add-ons: 2 bags</p>



# EVERYTHING PLANTER / EVERYTHING TABLE

The Everything Planter is suitable for indoor and outdoor use. The generous 34-litre capacity appears to float larger plants off the ground, giving the planter a visually light profile. No green thumb? Use it as an ice bucket at your next party.

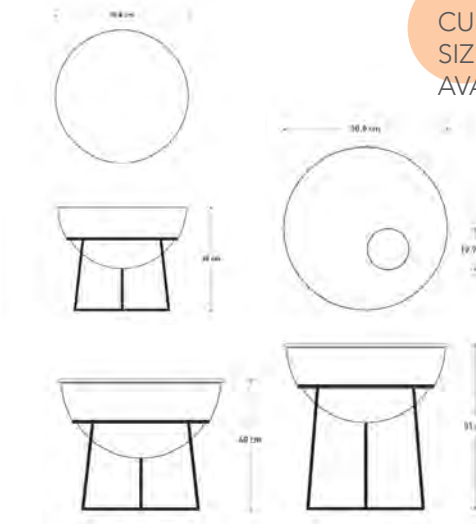

CUSTOM SIZES AVAILABLE

Visually inspired by Japanese Taiko drums, Use the Everything Table as a terrarium and to display your greenery in your home. Access the inside via a 5" inch hole opening in the glass.

# BABYLON LIGHT

Inspired by the hanging gardens of Babylon, the Babylon Light is a multifunctional pendant for those who love plants but not the clutter of flowerpots.

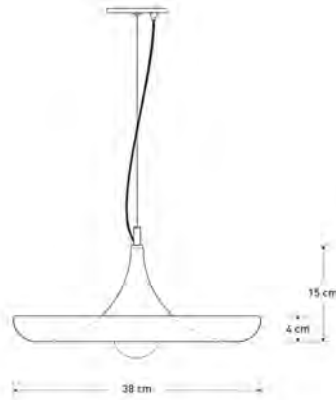

Materials: Powder-coated Spun Aluminum, Stainless Steel Cable, Nickel-plated Hardware  
 Dimensions: 38cm x 15cm / 15" x 6"  
 Drop Height: 182cm / 72"  
 Supply: 120 – 240v  
 Source: E26 lampholder, 60 watt max, Bulb not included  
 Canopy: Powder-coated Spun Steel, 15cm x 1cm / 5" x 0.5"  
 Colour: Gloss White

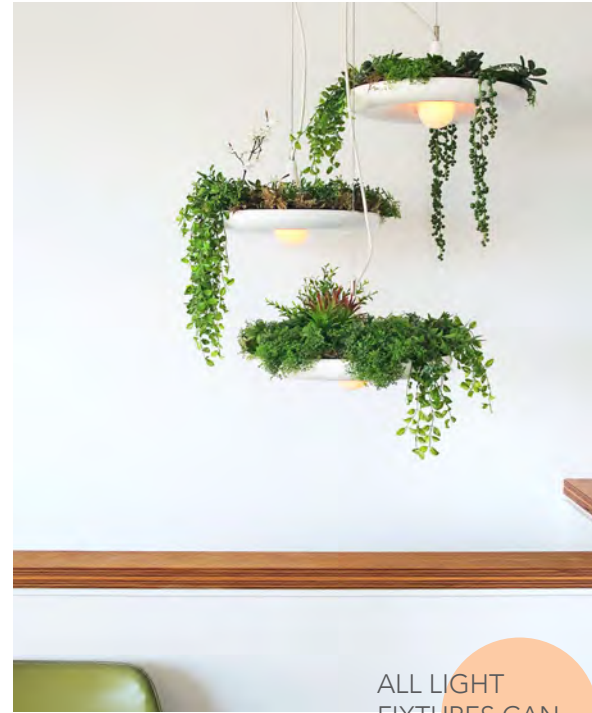

ALL LIGHT FIXTURES CAN BE PLANTED WITH LIVING, PRESERVED OR FAUX PLANTS



# WELL PLANTER LIGHT

The Well Light is both an evolution of design from the Babylon Light and a refined industrial pendant. The name comes from the use of a 'well glass' diffuser. The removable shade/basin allows for easy maintenance and more growing options such as herbs.

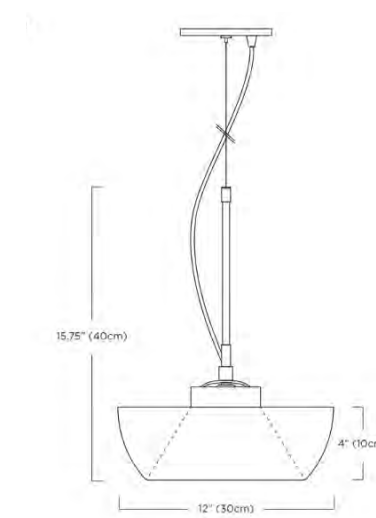
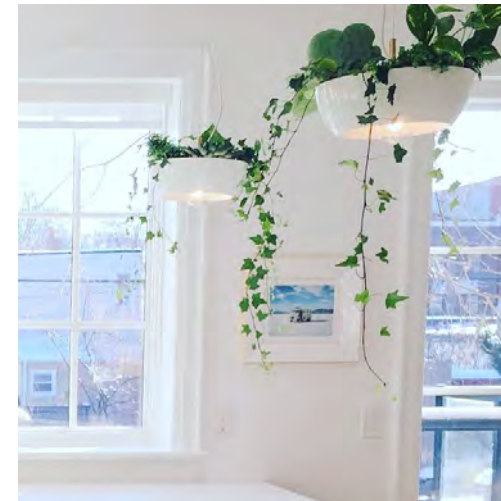

Materials: Powder-coated Spun and Cast Aluminum, Frosted Glass and Stainless Steel hardware  
 Dimensions: 30cm x 40 cm / 12" x 15.75"  
 Drop Length: 182 cm / 72"  
 Supply: 120 – 240v  
 Source: E26 lampholder, 60 watt max, Bulb not included  
 Canopy: Powder-coated Spun Steel, 30 cm x 10 cm / 12" x 4"  
 Colours: Dome — Satin White or Matte Black  
 Ring — Gloss White or Gloss Black  
 Shade — Gloss White or Gloss Black

# WELL PLANTER

Same design as the Well Planter Light, but with no light.

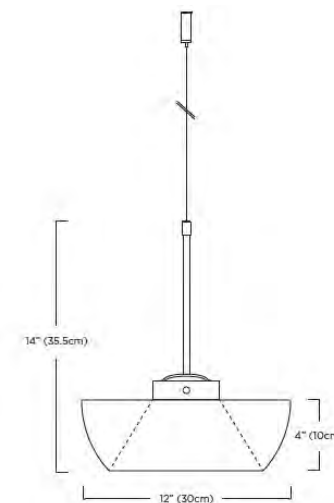

Materials: Aluminium, Brass, and Stainless Steel  
 Dimensions: 14" (35.5 cm) x 12" (30 cm)  
 Cable: Stainless steel, 72IN (182 cm)  
 Package Dimensions & Shipping: 12" (30 cm) x 12" (30 cm) x 6" (15 cm)  
 Weight: 2 LBS (1.125 KG)



# OPHILIA LINEAR PLANTER LIGHT

The Ophilia Linear Planter Light brings in both nature and light in a single product.

## CUSTOMIZE YOUR DESIGN

### LENGTH\*

- 3 ft
- 4 ft
- 5 ft

\*CUSTOM SIZES & COLOURS AVAILABLE

### FINISH\*

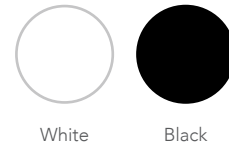

White      Black

### PLANTS



Preserved      Faux



# HEMISPHERE PENDANT PLANTER

Add a burst of colour to the soft curves and refined brass details of the Hemisphere Pendant while the opal glass diffuser will softly light your space.

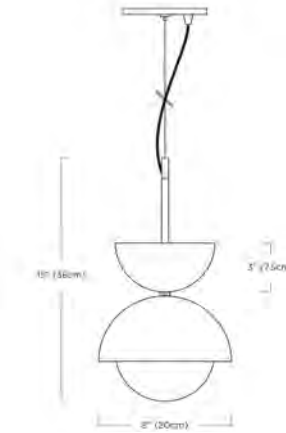
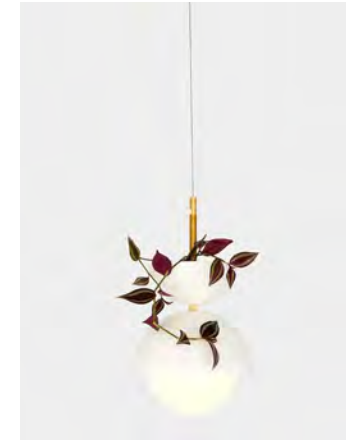

Materials: Aluminum, Brass, Stainless Steel, Opal Glass  
 Dimensions: 8" (20 cm) x 15" (38 cm)  
 Drop Length: 72" (182 cm)  
 Supply: 120 – 240v  
 Source: G9 lampholder, Bulb not included  
 Canopy: Powder-coated Steel 5" (15 cm) x 0.5" (1 cm)  
 Finishes: Aluminum: powder coated gloss white Brass: brushed, uncoated (will patina with use)

# HEMISPHERE PLANTER

Add a burst of colour to this unique hanging planter.

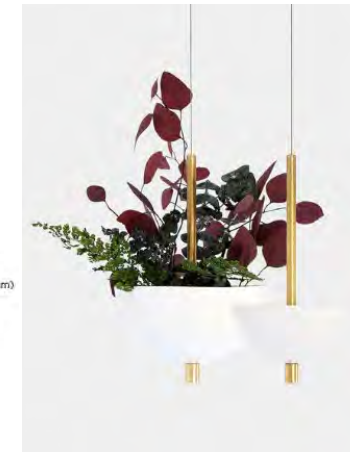
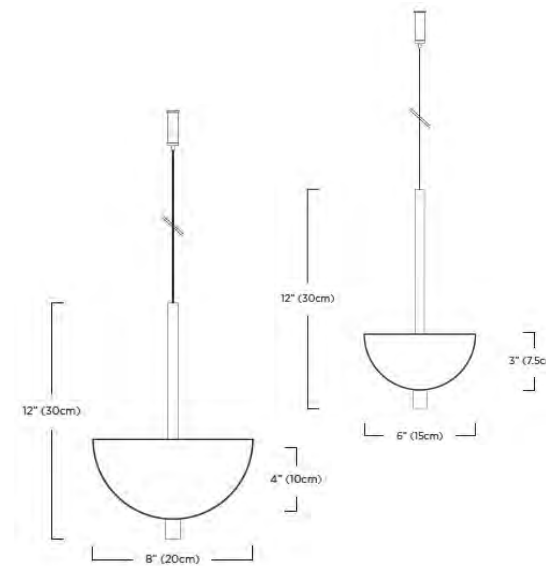

Materials: Aluminum, Brass, Stainless Steel  
 Dimensions: HP-WS: 6" (15 cm) Ø X 12" (30 cm)  
 HP-WL: 8" (20 cm) Ø X 12" (30 cm)  
 Cable: Stainless Steel, 72IN (182 cm)  
 Finishes: Aluminum: powder coated gloss white Brass: brushed, uncoated (will patina with use)





# NATURAL WALL COVERING

By Nature brings greenery indoors but not just greenery - we try to always offer sustainable solutions to surround plants and moss with quality products.

## NATURACORK

Great addition to any preserved product or on its own, our Naturacork LINE will bring natural textures to your space. It is a natural acoustic product, sustainable, hypo-allergenic and fire-retardant.



### CORK BRICKS

- Dimensions: 25/32" x 9 29/64" x 31 1/2" (20mm x 240mm x 800mm)
- One Tile = 2.07 sqft
- Coverage per carton: 22.77 sqft
- Tiles per carton: 11
- Finish: Water Based Polyurethane
- Material: 100% Cork
- Applications: wall
- Made in Italy



### CORK PANELS

- Dimensions: 55/64" x 12" x 24" (22mm x 304mm x 610mm)
- One Tile = 2 sqft
- Coverage per carton: 18.02 sqft
- Tiles per carton: 9
- Finish: Water Based Polyurethane
- Material: 100% Cork
- Applications: wall
- Made in Italy



# GENCORK

Gencork is a perfect sustainable choice for your indoor space as it combines elegance with ecological low-tech material. These cork panels are based on generative design.

- 100% natural and recyclable
- 95% energy self-sufficiency production
- Hypoallergenic properties
- Water and weather resistant
- Great sound absorber
- Preservation and respect for trees
- Misuse can cause product deterioration
- Digital fabrication
- Color changes with exposure to sunlight
- Scent is natural, non-toxic and disappears with time
- Made in Portugal

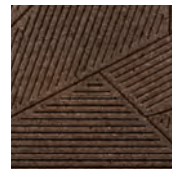

FOR MORE PATTERNS,  
ASK FOR FULL  
BROCHURE

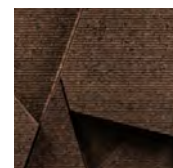
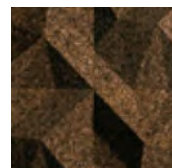
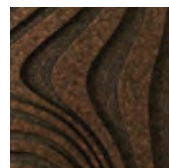
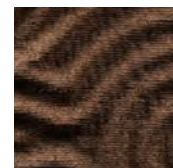

## ByNature Import Inc.

1.855.436.2919

[info@bynaturedesign.ca](mailto:info@bynaturedesign.ca)

[bynaturedesign.ca](http://bynaturedesign.ca)

### Vancouver

Unit #490 - 1000 Parker St  
Vancouver, BC V6A 2H2

### Toronto

20 Ashwarren Road  
North York, ON M3J 1Z5

### Québec

2001 Blvd Robert Bourassa, Suite 1700,  
Montreal, QC H3A 2A6

