

[BYNATURE]
Enjoy. Breathe. Feel good.

HEMISPHERE PLANTER



HEMISPHERE PLANTER

ADD A BURST OF COLOUR TO THIS UNIQUE HANGING PLANTER.

DESIGN: RYAN TAYLOR, 2018

—

MATERIALS

ALUMINUM, BRASS, STAINLESS STEEL

FINISHES

ALUMINUM — POWDER COAT: GLOSS WHITE

BRASS — BRUSHED, UNFINISHED (WILL PATINA WITH USE)

DIMENSIONS

HP-WS: 6" (15CM) Ø X 12" (30CM)

HP-WL: 8" (20CM) Ø X 12" (30CM)

CABLE

STAINLESS STEEL, 72IN (182CM)

PACKAGE DIMENSIONS

HP-WS

DIMENSIONS: 12" (30CM) X 6" (15CM) X 6" (15CM)

WEIGHT: 3 LBS (1.36 KG)

HP-WL

DIMENSIONS: 12" (30CM) X 9" (23CM) X 9" (23CM)

WEIGHT: 3 LBS (1.36 KG)

HP-WS

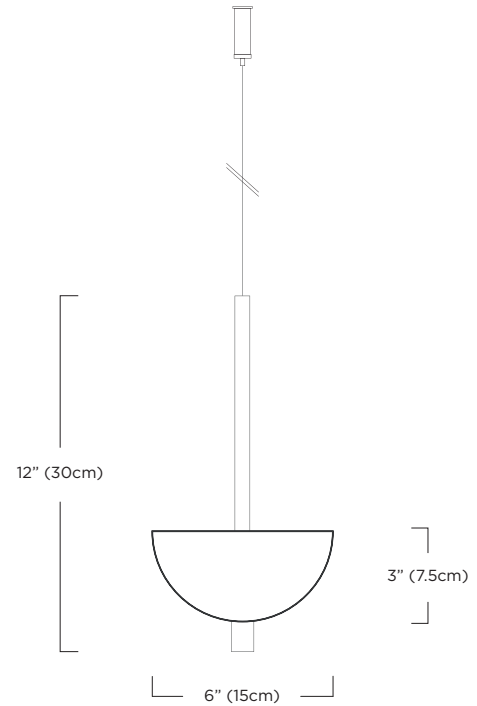

HP-WL

